



**naturedesign**

Collection 2026

# Collection 2026

design Gino Carollo

## Index

### **Tavoli - Dining table**

Blur	3 8 - 4 1
Cinnamon	3 4 - 3 7
Clay	1 2 - 1 7
Clover	0 2 - 0 9

### **Sedute - Seating**

Blend	2 8 - 3 3
Blossom	1 8 - 2 7

### **Divano**

Convivium	4 2 - 6 9
-----------	-----------

### **Madie - Sideboard**

Aura	7 8 - 8 5
------	-----------

### **Complementi - Complements**

April mirror	8 6 - 8 9
Balance coffe-table	7 0 - 7 7
Clover vase	1 0 - 1 1



**Clover** - Tavolo / Table

finiture: marmo Travertino e laccato lucido col. Ivory / finishes: Travertine marble and glossy lacquered base col. Ivory

**Blossom Armchair**- Sedia / Chair

finiture: tessuto Belsuede col. 003 / finishes: Belsuede col. 003 fabric





# Clover

design Gino Carollo

Clover è una collezione di tavoli caratterizzata da basi in poliuretano che richiamano la forma naturale da cui il progetto prende il nome e si distinguono per volumi abbondanti e soffici. Le diverse dimensioni consentono di rispondere con flessibilità a esigenze progettuali eterogenee, dagli spazi domestici agli ambienti più ampi e articolati, mentre l'ampia scelta di finiture per i piani, come legno, marmo e vetro cotto, e per le basi, come metallo luxor, materico e laccato, contribuisce a definirne di volta in volta il carattere.

*Clover is a collection of tables featuring polyurethane bases that recall the natural shape from which the project takes its name and are distinguished by their generous, soft volumes. The various sizes allow for a flexible response to a wide range of design needs, from domestic spaces to larger, more complex environments. The wide selection of finishes for the tops, such as wood, marble, and fired glass, and for the bases, such as Luxor, textured, and lacquered metal, contributes to defining each collection's unique character.*

## DISEGNI TECNICI / TECHNICAL DRAWINGS

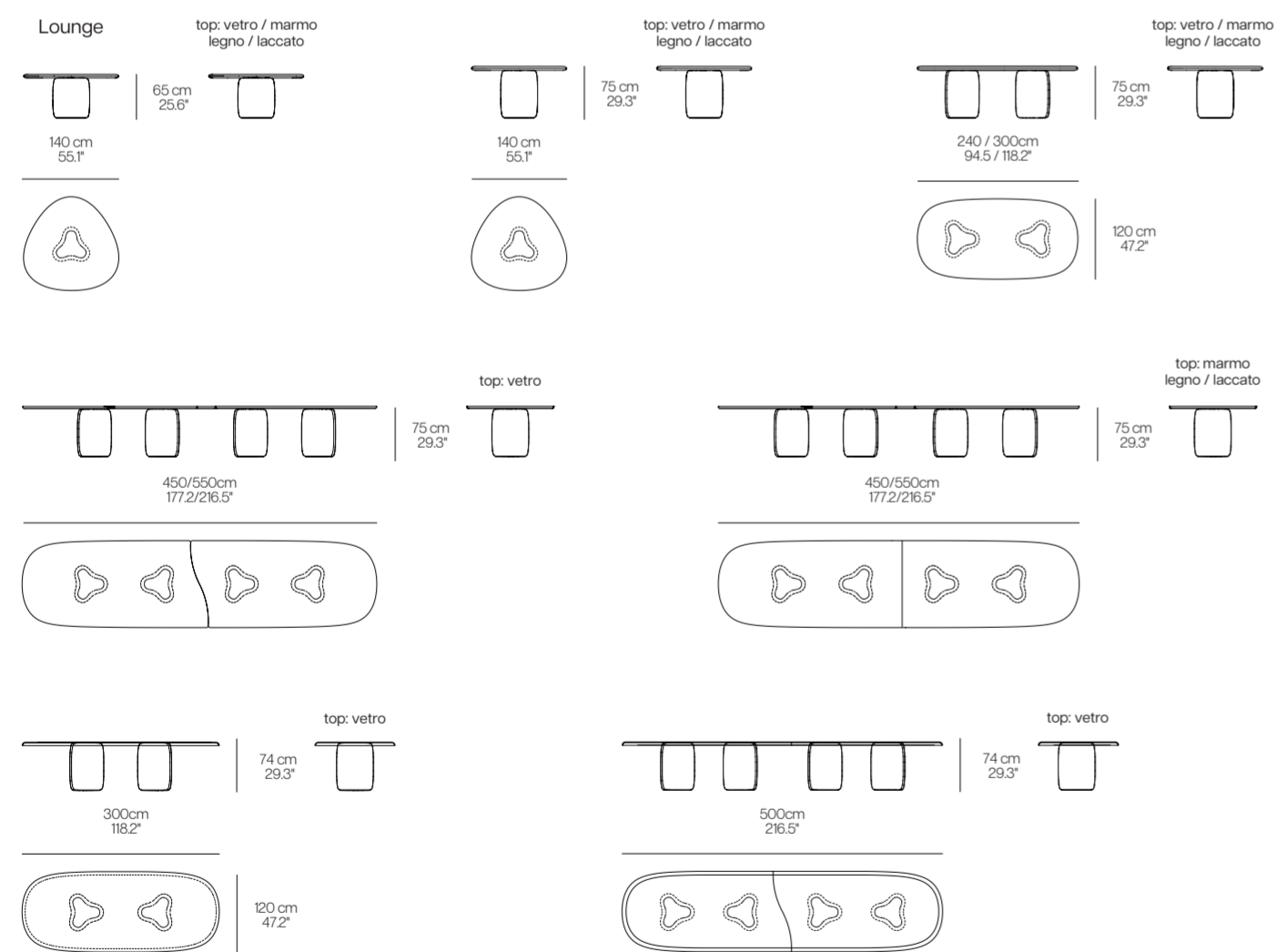

**Clover - Tavolo / Table**  
 finiture: vetro cotto retroverniciato  
 Sienna e laccato lucido col. Sienna/  
 finishes: Sienna tinted cast glass  
 and glossy lacquered col. Sienna

**Clover - Tavolo / Table**  
 finiture: vetro cotto retroverniciato  
 Taupe e laccato lucido col. Taupe/  
 finishes: Taupe tinted cast glass and  
 glossy lacquered col. Taupe

# Clover Vase

design Gino Carollo

La collezione di vasi Clover si compone di due versioni, caratterizzate da proporzioni differenti e realizzate in ceramica smaltata con finitura lucida o opaca. Le forme libere e arrotondate richiamano la base dell'omonimo tavolo, dando vita a un concetto di design scultoreo orientato alla continuità visiva. Non si tratta di semplici elementi decorativi, ma di presenze che "coronano" il tavolo, trasformandolo in una vera e propria installazione.

*The Clover vase collection consists of two versions, characterized by different proportions and made of glazed ceramic with a glossy or matte finish. The free-form, rounded shapes recall the base of the Clover table, creating a sculptural design concept focused on visual continuity. These are not simply decorative elements, but rather presences that "crown" the table, transforming it into a true installation.*

DISEGNI TECNICI / TECHNICAL DRAWINGS

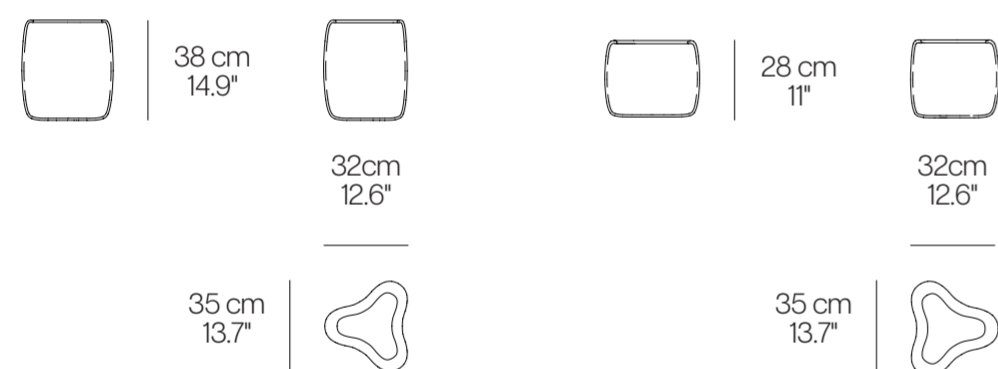

**Clover Vase - Vasi / Vases**  
 finiture: nero opaco  
 finishes: matte black



**Clover Vase - Vasi / Vases**  
 finiture: beige lucido  
 finishes: glossy beige



**Clay** - Tavolo / Table  
finiture: materico col. Taupe e marmo Travertino Titanium /  
finishes: materico col. Taupe and Titanium Travertine marble

**Blend** - Sedia / Chair  
finiture: tessuto Panda col. 01 / finishes: Panda col. 01 fabric



# Clay

design Gino Carollo

Le nuove varianti del tavolo Clay vanno ad ampliare la collezione dell'iconico tavolo dalla presenza dinamica e avvolgente. Per queste quattro nuove dimensioni, la sagoma del piano richiama la forma delle due basi che vengono raddoppiate per sostenere le nuove lunghezze. Clay è un pezzo d'arte funzionale, capace di incantare da ogni angolazione con i suoi affascinanti giochi di luci ed ombre, trasformando gli spazi in luoghi di stile e carattere.

*The new Clay table variations expand the collection of this iconic table, with its dynamic and enveloping presence. For these four new sizes, the top's shape echoes the form of the two bases, which are doubled to support the new lengths. Clay is a functional piece of art, capable of enchanting from every angle with its fascinating play of light and shadow, transforming spaces into places of style and character.*

## DISEGNI TECNICI / TECHNICAL DRAWINGS

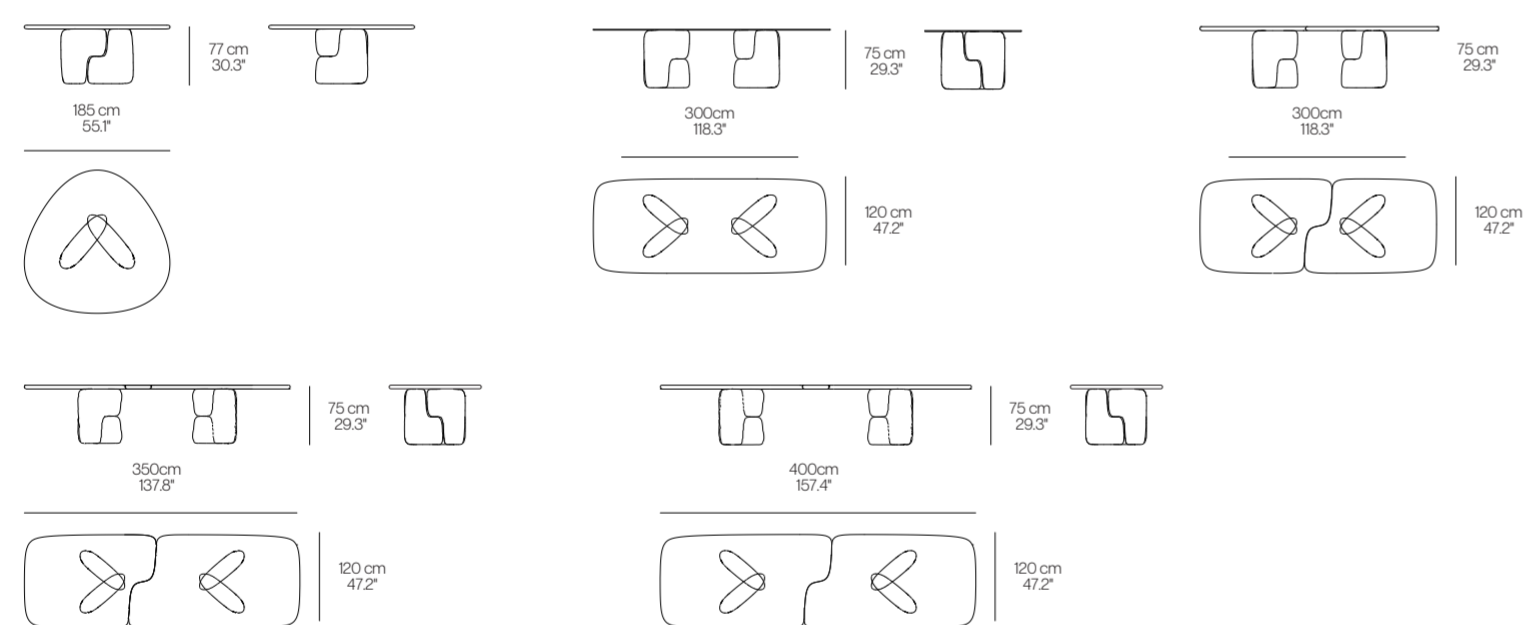

**Clay - Tavolo / Table**  
 finiture: materico col. Taupe e Travertino  
 Titanium / finishes: materico col. Taupe  
 and Titanium Travertine



**Clay - Tavolo / Table**  
 finiture: vetro cotto Bronze e materico  
 col. Taupe / finishes: Bronze cast glass  
 and materico col. Taupe



**Blossom Armchair- Sedia / Chair**  
finiture: tessuto Belsuede col. 003 /  
finishes: Belsuede col. 003 fabric









**Blossom Twist** - Sedia / Chair  
finiture: tessuto Panda col. 05 / finishes: Panda col. 05 fabric



# Blossom

design Gino Carollo

Il design dalle linee morbide e curve caratterizza lo schienale avvolgente della sedia Blossom. L'estetica elegante e versatile della seduta è completata dalla base girevole a 360°, completamente rivestita, che offre un'esperienza unica di mobilità e comfort. Stabilità e leggerezza si uniscono armoniosamente in questa sedia progettata per accompagnare ogni tuo spazio, grazie alle varianti di rivestimento in pelle, tessuto e nabuk.

*The Blossom chair's soft, curved lines characterize the enveloping backrest. The elegant and versatile aesthetic of the seat is complemented by the fully upholstered 360° swivel base, offering a unique experience of mobility and comfort. Stability and lightness blend harmoniously in this chair, designed to complement any space, thanks to the leather, fabric, and nubuck upholstery options.*

## DISEGNI TECNICI / TECHNICAL DRAWINGS

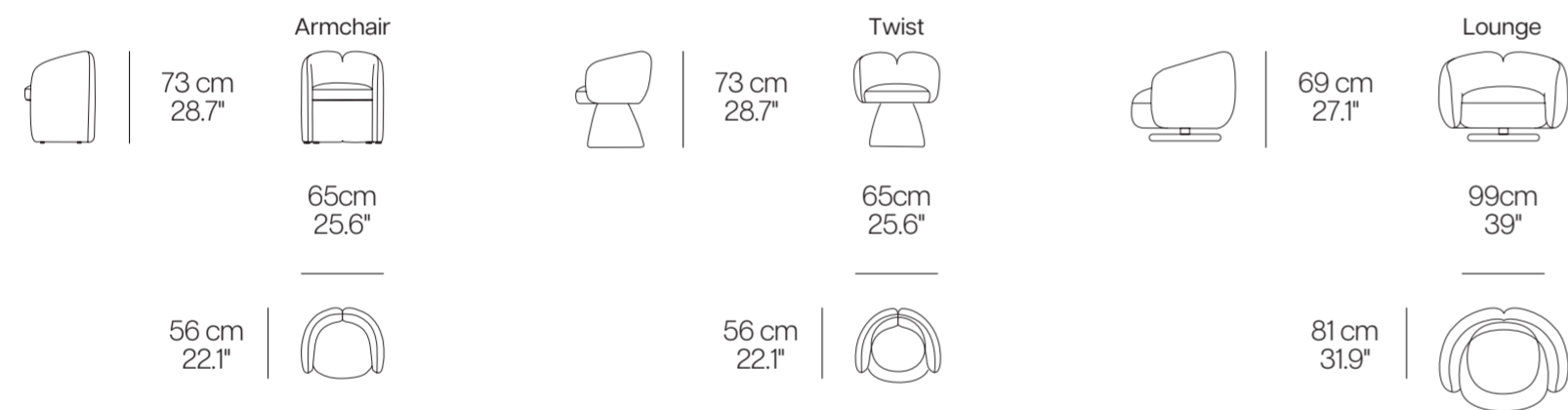

**Blossom Twist - Sedia / Chair**  
finiture: tessuto Panda col. 05 / finishes: Panda col. 05 fabric

**Blossom Armchair- Sedia / Chair**  
finiture: tessuto Belsuede col. 003 / finishes: Belsuede col. 003 fabric



**Blend - Sedia / Chair**  
finiture: tessuto Alpaca col. 06 / finishes: Alpaca col. 06 fabric



# Blend

design Gino Carollo

Blend si distingue per la sua comoda e accogliente imbottitura che ricopre l'intero corpo della sedia. Il design essenziale di linee curve è rivestito con una texture morbida e voluminosa per accentuare la sensazione di calore e comfort, grazie al rivestimento in tessuto o nabuk. Blend è una sedia distintiva e senza tempo, perfetta per caratterizzare ogni ambiente.

*Blend stands out for its comfortable and inviting padding that covers the entire body of the chair. The essential design of curved lines is covered with a soft, voluminous texture to accentuate the feeling of warmth and comfort, thanks to the fabric or nubuck upholstery. Blend is a distinctive and timeless chair, perfect for adding character to any space.*

## DISEGNI TECNICI / TECHNICAL DRAWINGS

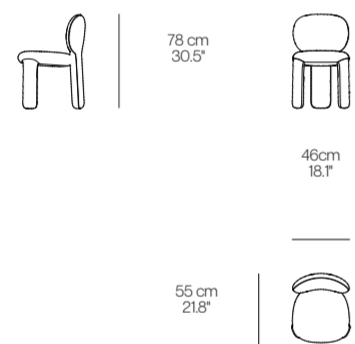

**Blend - Sedia / Chair**  
finiture: tessuto Panda col. 01 / finishes: Panda col. 01 fabric

**Blend - Sedia / Chair**  
finiture: tessuto Alpaca col. 06 / finishes: Alpaca col. 06 fabric



**Cinnamon** - Tavolo / Table  
finiture: vetro cotto Bronze / finishes: Bronze cast glass

**Blend** - Sedia / Chair  
finiture: tessuto Alpaca col. 06 / finishes: Alpaca col. 06 fabric

archiproducts  
AWARDS  
WINNER

# Cinnamon

design Gino Carollo

Tecnologia avanzata e design sofisticato si fondono per trasformare il vetro in un elemento fluido e armonioso in ogni dettaglio. Le basi curve in vetro cotto richiamano l'essenza sinuosa e avvolgente della cannella, conferendo al tavolo Cinnamon un carattere scultoreo distintivo. La sinergia tra forma e colore crea un'esperienza sensoriale coinvolgente e affascinante. Il piano in vetro si distingue per il bordo affusolato e curvo, che invita a sedersi e accoglie con comfort e leggerezza.

*Advanced technology and sophisticated design combine to transform glass into a fluid, harmonious element in every detail. The curved fired glass bases recall the sinuous and enveloping essence of cinnamon, giving the Cinnamon table a distinctive, sculptural character. The synergy between shape and color creates a sensory experience that engages and captivates. The glass top is distinguished by its tapered, curved edge, inviting you to sit and welcoming you with comfort and lightness.*

## DISEGNI TECNICI / TECHNICAL DRAWINGS

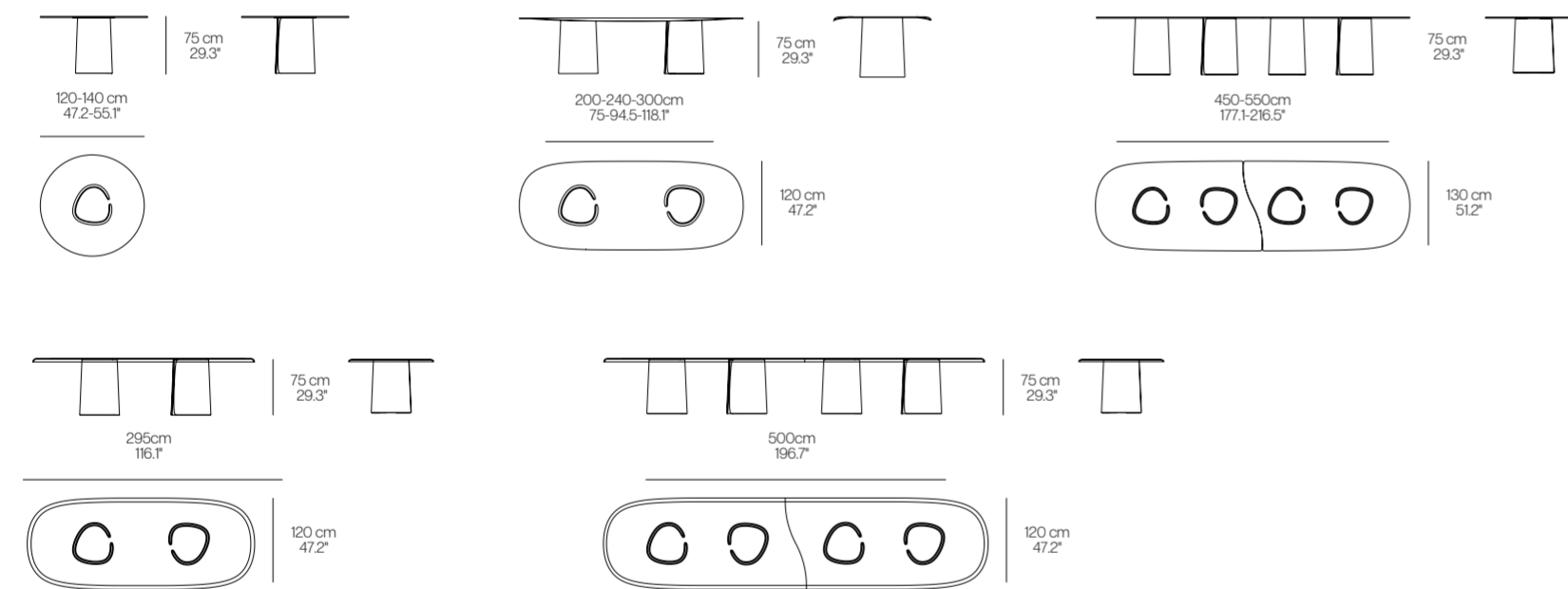

**Cinnamon** - Tavolo / Table  
finiture: vetro cotto Ambra /  
finishes: Ambra cast glass



**Cinnamon** - Tavolo / Table  
finiture: vetro cotto Bronze /  
finishes: Bronze cast glass



**Blur** - Tavolo / Table  
finiture: vetro cotto Amber / finishes: Amber cast glass

**Blossom Twist** - Sedia / Chair  
finiture: tessuto Panda col. 05 / finishes: Panda col. 05 fabric

# Blur

design Gino Carollo

La delicatezza delle curve e le forme morbide del tavolo Blur infondono un senso di fluidità alla sua immagine, che crea suggestivi effetti luminosi, grazie alla texture del vetro cotto, che permette alla luce di filtrare animando l'ambiente circostante. La base e il piano in vetro cotto sono disponibili in diverse varianti cromatiche, nasce così una geometria armonica fatta di scie di luce e colore.

*The delicate curves and soft shapes of the Blur table imbue its design with a sense of fluidity, creating evocative lighting effects thanks to the textured fired glass, which allows light to filter through, animating the surrounding space. The fired glass base and top are available in a variety of colors, creating a harmonious geometry of trails of light and color.*

## DISEGNI TECNICI / TECHNICAL DRAWINGS

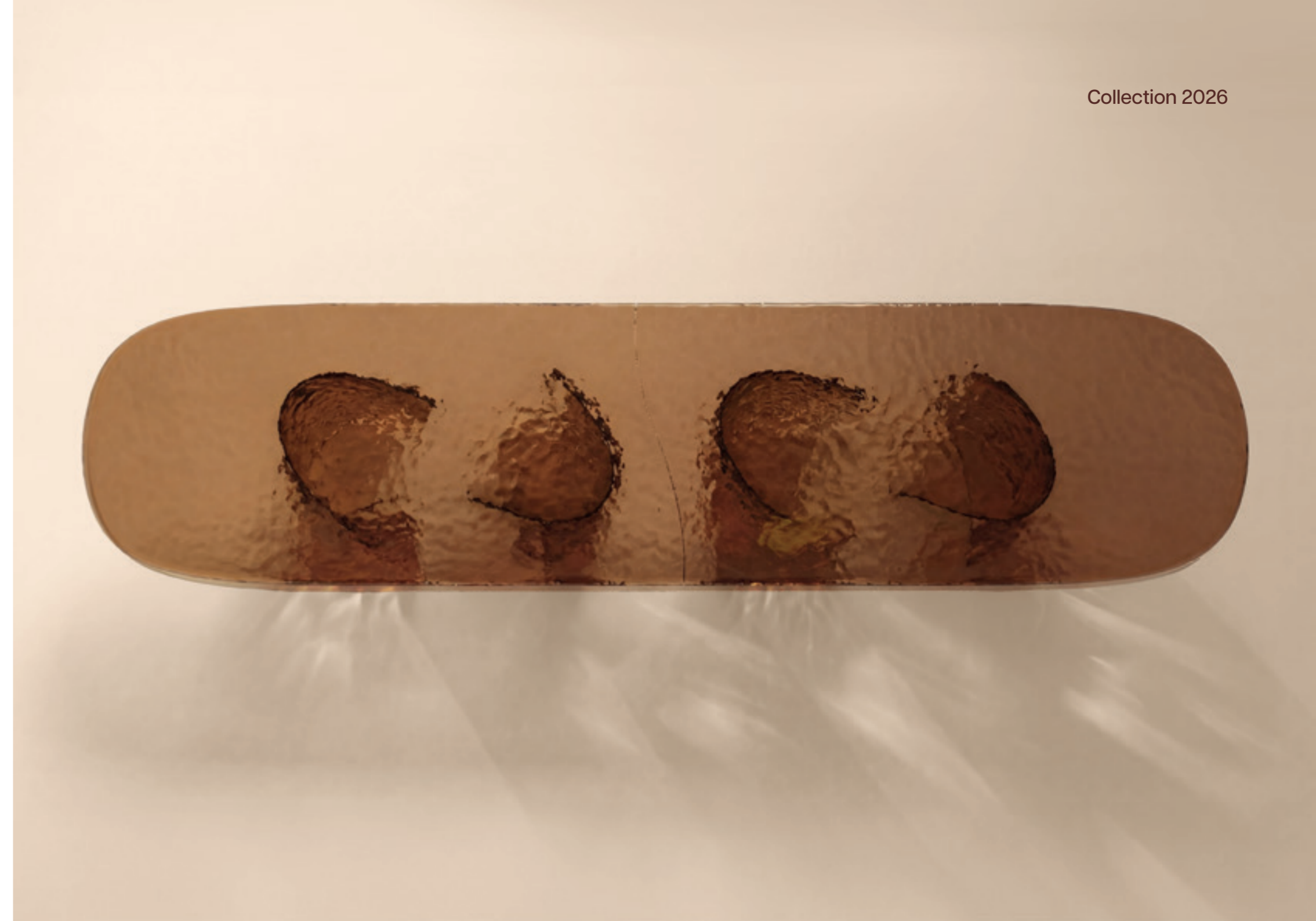
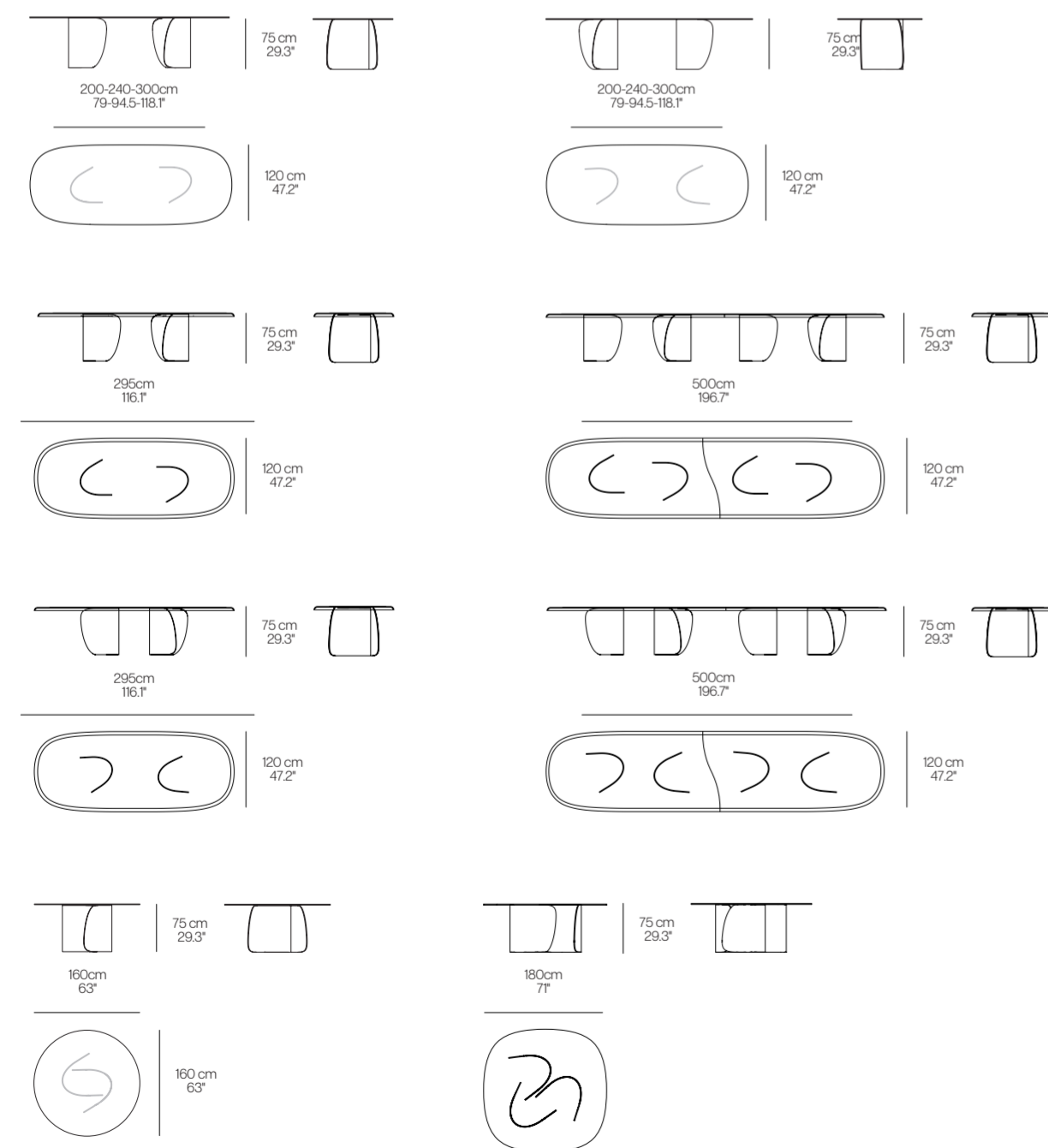

**Blur - Tavolo / Table**  
finiture: vetro cotto Bronze /  
finishes: Bronze cast glass



**Blur - Tavolo / Table**  
finiture: vetro cotto Ambra /  
finishes: Ambra cast glass



**Convivium** - Divano / Sofa  
finiture: tessuto Alpaca col. 02 / finishes: Alpaca col. 02 fabric



**Convivium** - Divano / Sofa  
finiture: tessuto Alpaca col. 02 / finishes: Alpaca col. 02 fabric





**Convivium** - Divano / Sofa  
finiture: tessuto Belsuede col. 033 / finishes: Belsuede col. 033 fabric





**Convivium** - Divano / Sofa  
finiture: tessuto From Nature col. 001 / finishes: From Nature col. 001 fabric

# Convivium

design Gino Carollo

Convivium è una famiglia di divani ed elementi multifunzionali che unisce comfort, modularità e versatilità. Pensato per ambienti domestici e spazi condivisi, si distingue per il design accogliente e per la capacità di dare vita a configurazioni fluide e conviviali. Evoluzione del divano classico, è composto da elementi individuali che possono essere uniti e combinati per creare spazi dinamici e confortevoli.

*Convivium is a family of sofas and multifunctional elements that combine comfort, modularity, and versatility. Designed for both domestic and shared spaces, it stands out for its welcoming design and its ability to create fluid and convivial configurations. An evolution of the classic sofa, it is composed of individual elements that can be joined and combined to create dynamic and comfortable spaces.*

## DISEGNI TECNICI / TECHNICAL DRAWINGS

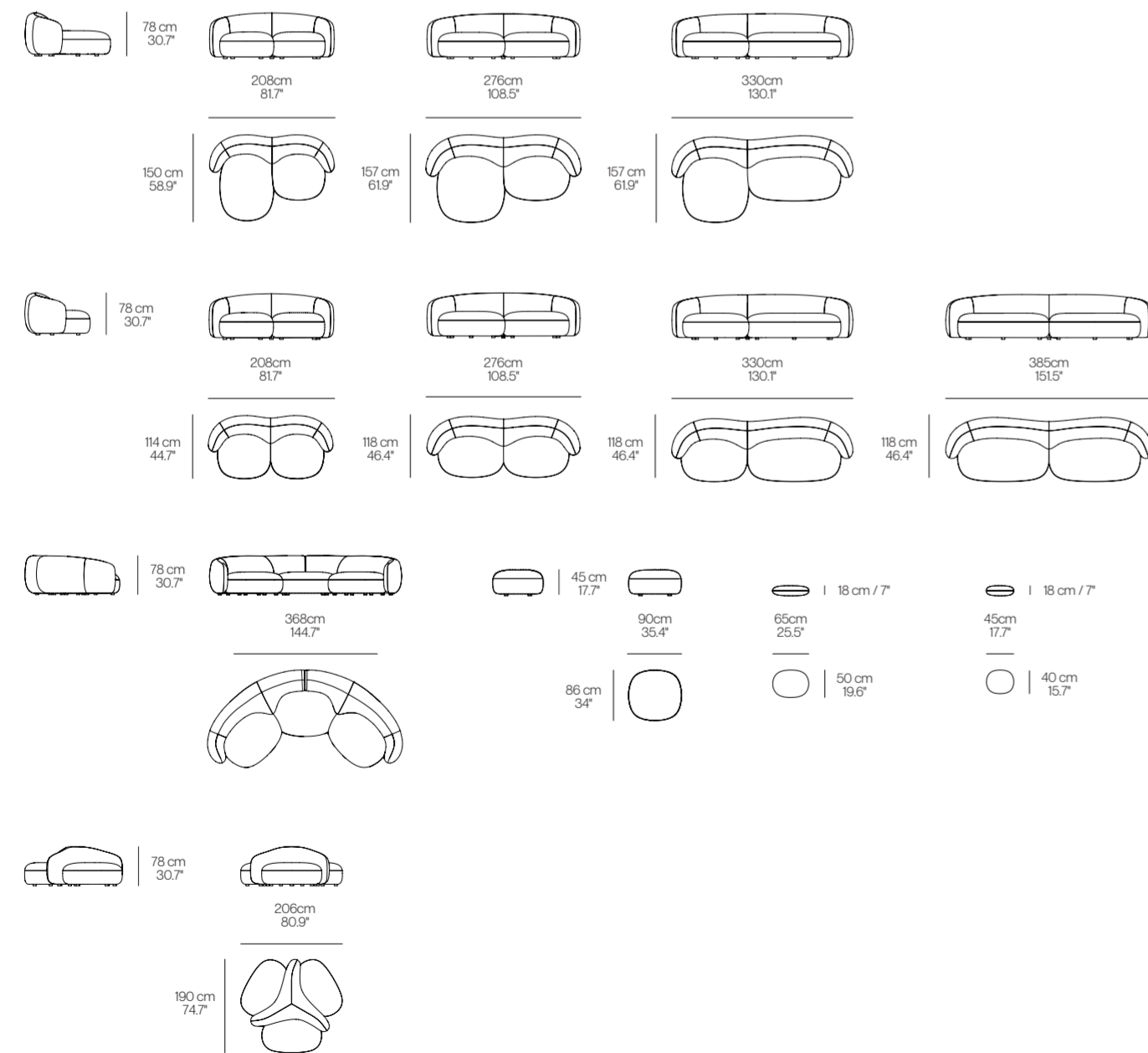

**Convivium - Divano / Sofa**  
 finiture: tessuto Panda col. 01 /  
 finishes: Panda col. 01 fabric

**Convivium - Divano / Sofa**  
 finiture: tessuto Panda col. 01 /  
 finishes: Panda col. 01 fabric

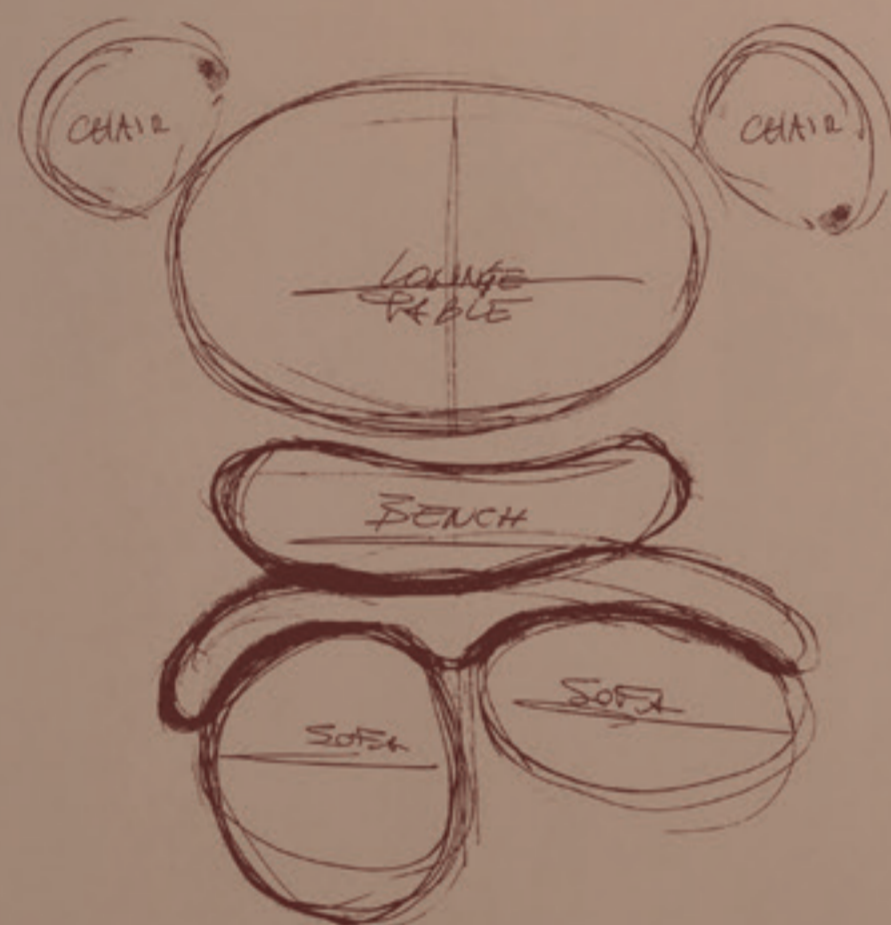
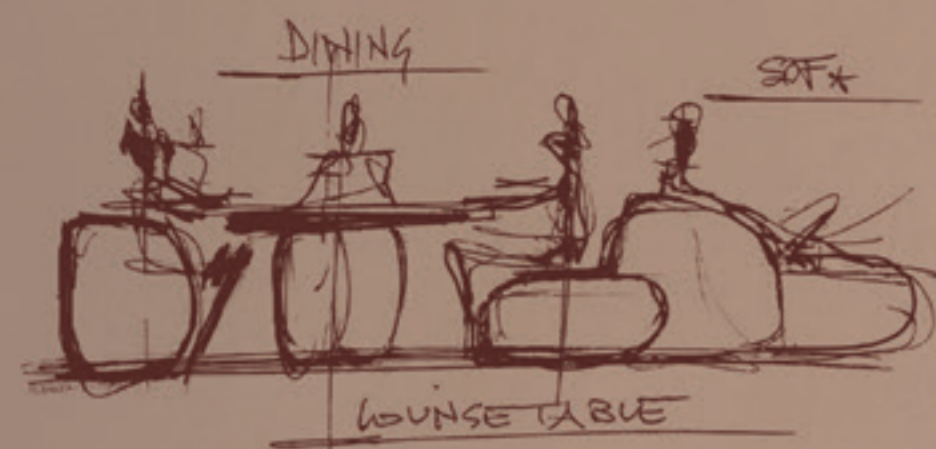

## Convivium

concept design Gino Carollo

Il sistema Convivium è una famiglia di divani, poltrone e panche, elementi multifunzionali sia per la zona giorno che per spazi collettivi.

Completato con l'inserimento del tavolo Clover, crea aree conviviali dove i confini tra zona pranzo, meeting e relax si dissolvono. Un'evoluzione del divano classico, composto da elementi individuali uniti e combinati per spazi dinamici e confortevoli.

*The Convivium system is a family of sofas, armchairs, and benches, multifunctional elements for both living areas and shared spaces.*

*Completed with the Clover table, it creates convivial spaces where the boundaries between dining, meeting, and relaxation dissolve. An evolution of the classic sofa, composed of individual elements joined and combined for dynamic and comfortable spaces.*





**Clover** - Tavolo / Dining table  
finiture: lucido col. Sienna / finishes: glossy lacquered col. Sienna

**Convivium** - Divano / Sofa  
finiture: tessuto Alpaca col. 02 / finishes: Alpaca col. 02 fabric

**Blossom Lounge** - Poltrona / Armchair  
finiture: tessuto Alpaca Alto col. 020 / finishes: Alpaca Alto col. 020 fabric



**Clover** - Tavolo / Dining table  
finiture: lucido col. Sienna / finishes: glossy lacquered col. Sienna

**Convivium** - Divano / Sofa  
finiture: tessuto Alpaca col. 02 / finishes: Alpaca col. 02 fabric

**Blossom Lounge** - Poltrona / Armchair  
finiture: tessuto Alpaca Alto col. 020 / finishes: Alpaca Alto col. 020 fabric









**Clover** - Tavolo / Dining table

finiture: lucido col. Taupe e vetro cotto retroverniciato Taupe /  
finishes: glossy lacquered col. Taupe and Taupe tinted cast glass

**Convivium** - Divano / Sofa

finiture: tessuto Panda col. 01 / finishes: Panda col. 01 fabric

**Blossom Twist** - Sedia / Chair

finiture: tessuto Panda col. 05 / finishes: Panda col. 05 fabric

# Convivium

design Gino Carollo

Il sistema Convivium è una famiglia di divani, poltrone e panche, elementi multifunzionali sia per la zona giorno che per spazi collettivi.

Completato con l'inserimento del tavolo Clover, crea aree conviviali dove i confini tra zona pranzo, meeting e relax si dissolvono. Un'evoluzione del divano classico, composto da elementi individuali uniti e combinati per spazi dinamici e confortevoli.

*The Convivium system is a family of sofas, armchairs, and benches, multifunctional elements for both living areas and shared spaces.*

*Completed with the Clover table, it creates convivial spaces where the boundaries between dining, meeting, and relaxation dissolve. An evolution of the classic sofa, composed of individual elements joined and combined for dynamic and comfortable spaces.*

DISEGNI TECNICI / TECHNICAL DRAWINGS

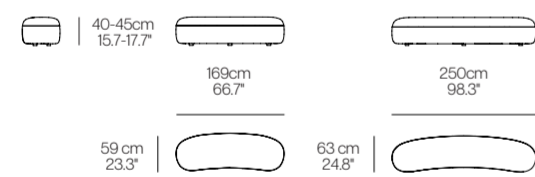
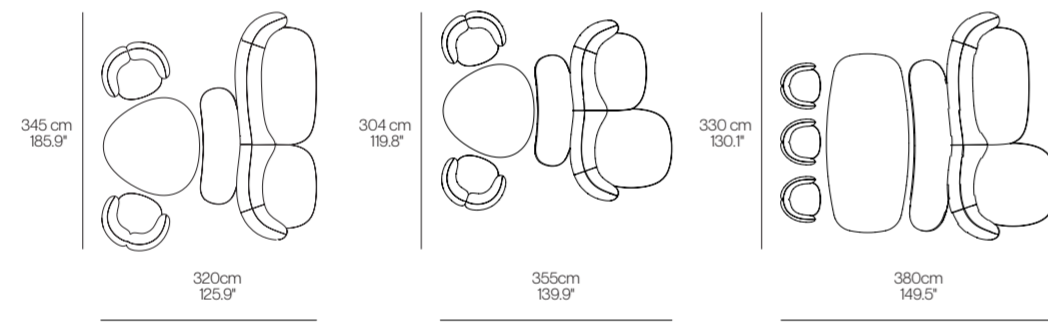

**Clover - Tavolo / Table**  
 finiture: vetro cotto retroverniciato  
 Sienna e laccato lucido col. Sienna/  
 finishes: Sienna tinted cast glass  
 and glossy lacquered col. Sienna



**Clover - Tavolo / Table**  
 finiture: vetro cotto retroverniciato  
 Taupe e laccato lucido col. Taupe/  
 finishes: Taupe tinted cast glass  
 and glossy lacquered col. Taupe





**Convivium** - Divano / Sofa  
finiture: tessuto Belsuede col. 033 / finishes: Belsuede col. 033 fabric

**Balance** - Tavolini / Coffe-table  
finiture: vetro cotto Bronze e laccato lucido col. Umber e Taupe /  
finishes: Bronze cast glass and glossy lacquered col. Umber and Taupe



**Balance** - Tavolini / Coffee- tables  
finiture: vetro cotto retro verniciato Sienna e  
laccato lucido col. Sienna /  
finishes: Sienna tinted cast glass and glossy  
laquered col. Sienna





**Convivium** - Divano / Sofa  
finiture: tessuto Alpaca col. 02/ finishes: Alpaca col. 02 fabric

**Balance** - Tavolini / Coffe-table  
finiture: marmo Travertino e laccato lucido col. Ivory e Taupe /  
finishes: Travertine marble and glossy lacquered col. Ivory and Taupe

# Balance coffee-table

design Gino Carollo

La collezione di tavolini Balance è composta da tre versioni dalle diverse proporzioni, da accostare in soluzioni monocromatiche in finitura laccata, disponibile in quattro varianti colore, oppure a contrasto, con l'inserimento di piani in marmo o vetro per creare vere e proprie composizioni dinamiche di grande effetto. Le forme libere e arrotondate sono completate dai profili arrotondati per agevolare composizioni ampie e regolari di più pezzi.

*The Balance coffee table collection comprises three versions with different proportions, which can be combined in a single-color lacquered finish, available in four color variations, or in contrasting versions with the addition of marble or glass tops to create truly dynamic compositions with a striking effect. The free-flowing, rounded shapes are complemented by rounded profiles to facilitate large, regular compositions of multiple pieces.*

DISEGNI TECNICI / TECHNICAL DRAWINGS

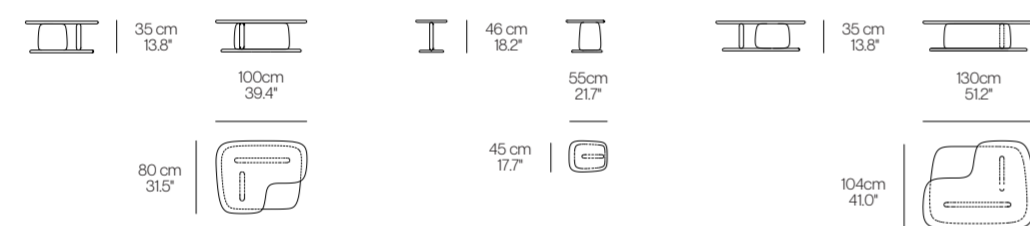

**Balance - Tavolini / Coffee- tables**  
 finiture: vetro cotto retro verniciato  
 Sienna e laccato lucido col. Sienna /  
 finishes: Sienna tinted cast glass and  
 glossy laquered col. Sienna



**Balance - Tavolini / Coffee- tables**  
 finiture: vetro cotto Bronze,  
 materico col. Ivory e col. Taupe /  
 finishes: Bronze cast glass, materico  
 col. Ivory and col. Taupe



**Aura** - Madie / Sideboard  
finiture: vetro cotto bronze fumè e argento retro vernicato specchio/  
finishes: bronze, smoked and silver tinted mirrored cast glass





**Aura** - Madie / Sideboard  
finiture: vetro cotto argento retro vernicato  
specchio / finishes: silver tinted mirrored cast glass

# Aura

design Gino Carollo

La madia Aura in vetro cotto specchiato con dettagli in ottone, è stata pensata con l'obiettivo di trovare una soluzione versatile e scenografica per la zona giorno. La finitura a specchio la rende un elemento capace di coniugare estetica e praticità, riflettendo la luce e ampliando visivamente gli spazi. La forma pulita lo rende perfettamente coniugabile per ogni spazio e stile.

*The Aura sideboard, in mirrored baked glass with brass details, was thought with the aim of providing a versatile and striking solution for the living area.*

*The mirrored finish makes it a piece capable of combining aesthetics and practicality, reflecting light and visually enlarging spaces. The clean shape makes it a perfect fit for any space and style.*

## DISEGNI TECNICI / TECHNICAL DRAWINGS

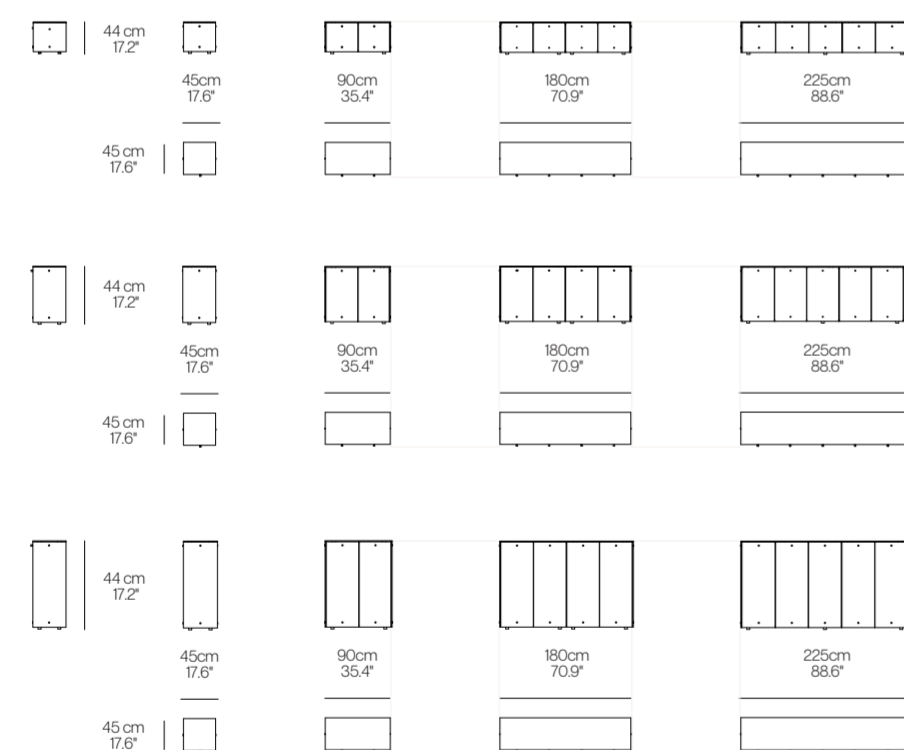

**Aura - Madie / Sideboard**  
 finiture: vetro cotto argento retro vernicato  
 specchio/ finishes: silver tinted mirrored cast glass



**April** - Specchi / Mirrors  
finiture: argento / finishes: silver



# April

design Gino Carollo

Lo specchio April esplora forme organiche e armoniose, trasformando un semplice specchio funzionale in un elemento decorativo da parete.

Lo specchio può essere appeso in due diversi modi, per poter essere accoppiato ampliando la superficie di riflessione ed aumentando la luminosità dell'ambiente.

*The April mirror explores organic and harmonious forms, transforming a simple, functional mirror into a decorative wall element.*

*The mirror can be hung in two different ways, allowing it to be paired together to expand the reflective surface and brighten the room.*

## DISEGNI TECNICI / TECHNICAL DRAWINGS

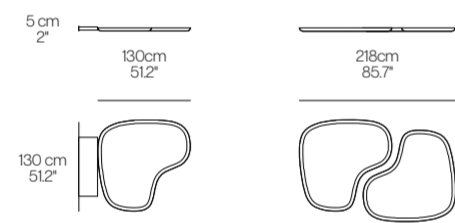

**April - Specchi / Mirrors**  
finiture: specchio argento e bronzo /  
finishes: silver and bronze mirror



**April - Specchio / Mirror**  
finiture: specchio argento /  
finishes: silver mirror

#### Art direction

Gino Carollo

#### Visual content

Gino Carollo Studio  
Isabella Roccoberton  
Alessia Saccardo

#### Pre-press & Printing

Opero  
Formo

#### Contributing writers

Enrica Mariani

#### CGI

Studio 28 Gino Carollo

#### THANKS

OH!Hi Lab Ceramic  
Ceramiche Milesi

Copyright © 2026 Naturedesign

All rights reserved for all text, layout and images.

No text, layout or pictures may be used or reproduced for commercial purposes by third parties, including dealers, retailers, internet shops and other, without the prior written approval by Nature Design.

Nature Design reserves the right to change, without any notice, materials, covers, finishes and drawings of the products of this catalogue.  
Colors and finishes shown are approximate and may differ from actual ones.

All rights reserved for all text, layout and images.

No text, layout or pictures may be used or reproduced for commercial purposes by third parties, including dealers, retailers, internet shops and other, without the prior written approval by Nature Design.

Nature Design reserves the right to change, without any notice, materials, covers, finishes and drawings of the products of this catalogue.  
Colors and finishes shown are approximate and may differ from actual ones.

[www.naturedesign.com](http://www.naturedesign.com)

Cerea, Verona - Italy  
Tel. +39 (0)442 321236  
[info@naturedesign.com](mailto:info@naturedesign.com)

**naturedesign**

[www.naturedesign.com](http://www.naturedesign.com)